



A&D Apollo



GF-4002A



GX-1003A



GX-224AE



*Taking Weighing Precision
and Protection to New Heights*

Simply Created for Practical Purposes

All the innovative technologies of A&D Apollo are designed to provide functional solutions for real world problems that users face in laboratories or in factories. Now discover what they are, and what precision, protection, performance and productivity really mean to you!

Smart SHS®

Smart super hybrid sensor (Smart SHS) realizing wide lineup from analytical to high-resolution, high-capacity precision models

Select a balance that best suits your applications and budgets from either the GX-A series of 16 models with internal calibration function (three 0.0001 g readability models, six 0.001 g readability models, five 0.01 g readability models and two 0.1 g readability models) or the GF-A series of 18 models without internal calibration function (three 0.0001 g readability models, seven 0.001 g readability models, six 0.01 g readability models and two 0.1 g readability models).

In addition, the GX-AE series, which consists of three 0.0001 g readability models with internal calibration function, has an ionizer embedded in its breeze break for quickly eliminating static from the sample.

Analytical

GX-AE series (d = 0.0001 g)

Built-in fanless ionizer

Adopting A&D's original "Quick Ion" technology, it removes static at twice the speed of the conventional ionizer (approx. 0.3 seconds*1 when the target object is within a distance of 10 cm) without any disturbance.

◆ Patent pending

*1 Subject to the ambient environment, shape of the target object and amount of static charge.

Antistatic glass panes

The glass panes of the breeze break are coated with transparent evaporated metal to block static from outside.

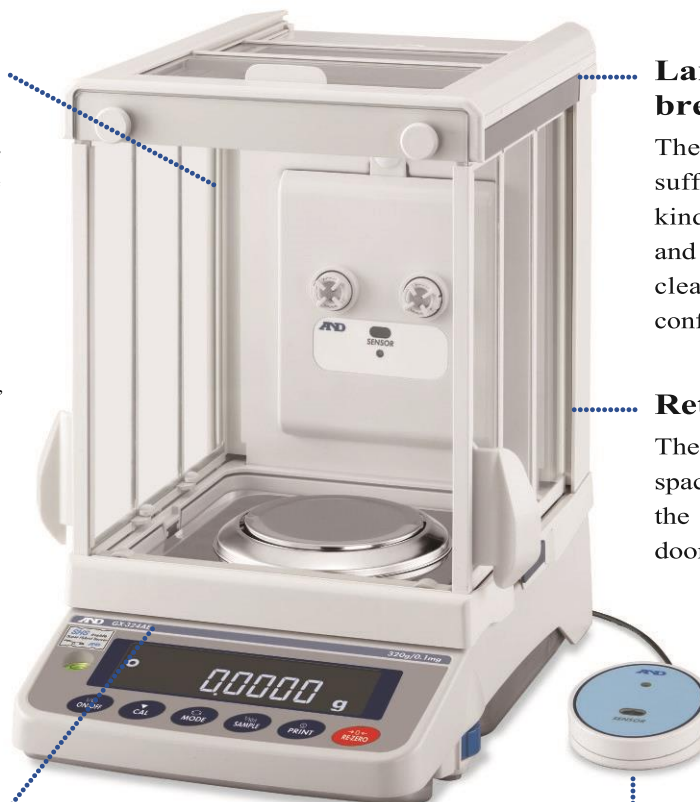

Large and detachable breeze break

The breeze break provides sufficient room for various kinds of containers/fixtures and can be easily removed for cleaning as well as use in confined space.

Retractable doors

The balance requires no extra space at the rear for accessing the weighing chamber, as the doors disappear into the back.

External IR switch

The GX-AE series comes standard with a touchless switch to activate the ionizer for a set duration.

GX-A series (d = 0.0001 g)



GF-A series (d = 0.0001 g)



Precision

GX-A series (d = 0.001 g)



GF-A series (d = 0.001 g)



GX-A series (d = 0.01/0.1 g)



GF-A series (d = 0.01/0.1 g)



Fast stabilization

A combination of a high-stiffness, Roberval-structure spring material and an electromagnetic force restoration mechanism simultaneously realizes fast stabilization and high resolution for efficient, precise weighing. Typical stabilization time is from 1.5 to 2 seconds with the 0.0001 g readability models and 1 second with the 0.001/0.01/0.1 g readability models.*²

*² Excludes the 1,620 g × 0.001 g and 10,200 g × 0.01 g models, with a typical stabilization time of 1.5 seconds.

Long-term durability and low cost of ownership

A&D's internal experiment verified that Smart SHS withstood a durability test of 10 million repeated loadings without issue. With proper usage and care it can maintain a long and functional life. In case damage is caused, only the defective parts, not the whole unit, need to be replaced, incurring a minimal cost.

Internal weight (for the GX-AE/GX-A series)

Automatic self calibration (ASC)

To ensure accuracy all the time, the balance can be set to calibrate itself automatically using its internal weight either (1) in response to change in ambient temperature to prevent error due to sensitivity drift, (2) at a set interval time, or (3) at predetermined (up to three) times of the day. Internal calibration can also be performed any time with one key press.

Internal weight value correction

In cases such as where the internal weight value varied over time, it can be corrected either by loading an external weight whose value the balance uses as a reference or by manually inputting a correction value.

ECL

Electronically controlled load (ECL) that enables precision management without using an external weight

ECL is A&D's unique technology of generating a minute load (0.3 to 3% of the balance capacity) by purposely altering the equilibrium state of the electromagnetic force restoration sensor. ♦ Equipped with this ECL, A&D Apollo can automatically assess its precision and provide a number of valuable indexes. The entire process takes only 1.5 minutes and can be readily included in a daily check SOP.

♦ Patented



Dia-Check

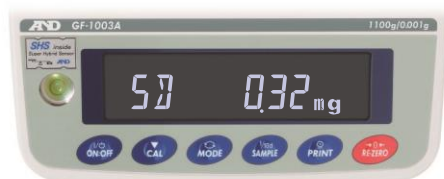

Standard Deviation



QuickMin-S

Dia-Check

Auto precision assessment (APA)

The balance first makes quick diagnoses on whether there is a critical failure to give users peace of mind to proceed with daily weighing routines.

Standard Deviation

Following Dia-Check, the balance goes on to perform 10 repeated measurements with ECL to calculate a standard deviation,^{*3} allowing users to quickly assess the balance repeatability under any given environment.

QuickMin-S

Based on the standard deviation obtained through ECL, the balance quickly indicates the minimum weight^{*4} by a tolerance of either 0.1% in accordance with the United States Pharmacopeia (USP) Chapter 41, or 1%, depending on the laboratory requirements.

*
*³⁴ The unit of measure will be mg only. The unit of measure will be g only

Adjustable response characteristics

Depending on the APA results above, you can trade weighing speed for higher display stability*⁵ or vice versa by selecting one of three preset response characteristics (FAST, MID or SLOW).

*⁵ This is not to improve repeatability.

Features effective for specific applications

Use in production lines

The weight sensor of a high-precision balance will be damaged in a short period if it is continuously affected by loads with acceleration (impact shocks). This typically occurs in factories where materials are placed roughly by machines or thrown by operators onto balances. In addition, impact shocks can easily shift values and cause errors.

The difficulty is that even if you know the above, you may not know what degree of impact shock is safe or unsafe for the balance to take preventive measures as necessary.

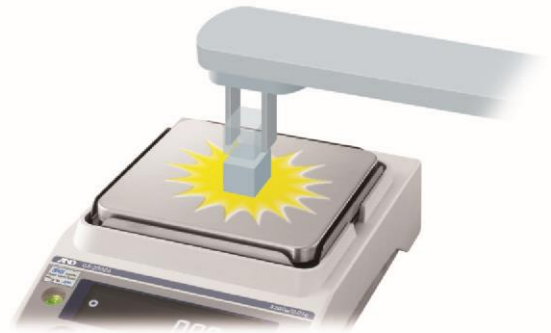

ISD

Impact shock detection (ISD) providing feedback to prevent damage to the weight sensor

Impact-Alert

A&D Apollo visualizes the magnitudes of impact shocks that its Smart SHS receives at four levels. It beeps once at Level 3 and twice at Level 4 (both of which should be avoided).

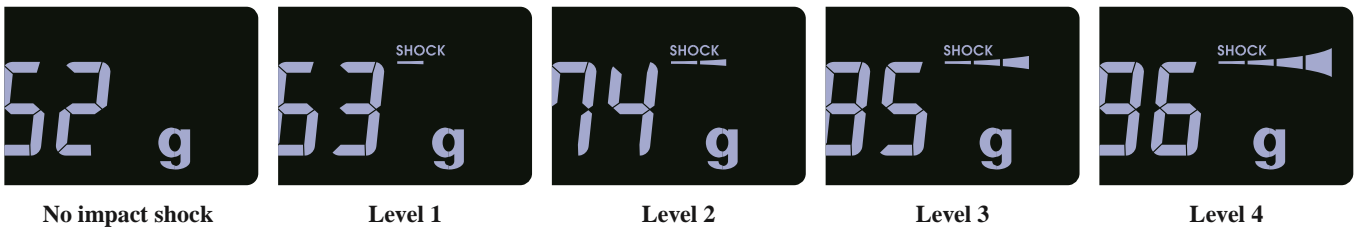

Shock-Log

While the power is on, up to 50 impacts of Level 3 and Level 4 will be stored in the balance with timestamp (and log-in user information when the password lock function is used). Data will then be overwritten in order from the weakest impact. This function is especially beneficial for quality managers as it enables them to check and show how the balance had been treated when returned for repair.

Cushioning and overload protection mechanism

The two leaf springs (or one cruciform spring for the 0.0001 g readability models) that support the weighing pan mitigate impact shocks significantly. Meanwhile, Smart SHS is well protected against vertical and transverse static overloading. It won't break due to malfunction of the weighing system's actuator and the resulting excess load. A&D's testing demonstrated that even a human did no damage to the balance by stepping on it.



Flow rate measurement

Flow rate is determined from the weight variation that occurs during a given interval. Many operators time this interval by using a stopwatch. Besides being troublesome and error-prone, this method does not allow precise recording of flow rates that vary from moment to moment because the interval used to divide the weight variation (calculation time) is too long.

Alternatively, a PC can be connected to the balance to take the weighing data and perform the calculation. This method enables measurement to be more responsive to flow rate changes by shortening the calculation time. However, due to the syncing problems that inevitably occur between the internal clocks of the balance and the PC, the timing at which the balance receives the command from the PC to send the weight value and its display refresh cycle gradually go out of alignment. In consequence, the PC intermittently produces irregular values even when the actual flow rate is constant.

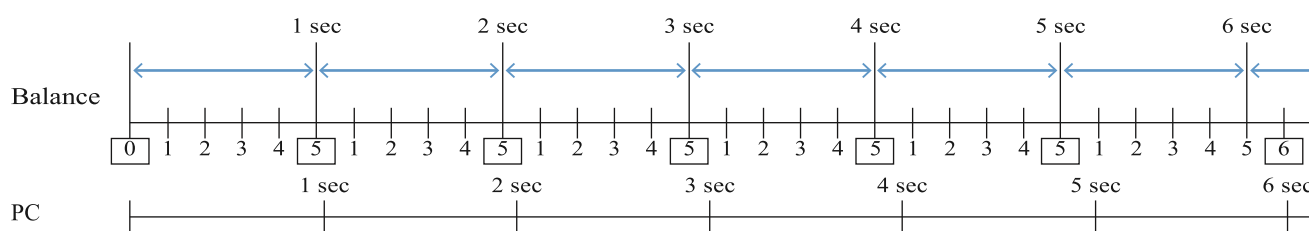

Time disparity of two different internal clocks when the balance display refresh rate is 5 times/sec, the calculation time is 1 sec, and the balance's internal clock goes slightly ahead of the PC's

FRD

Flow rate display (FRD) for calculating flow rate with the balance itself

FR-Cal

A&D Apollo can calculate and display/output the mass flow rate (the unit of measure can be selected from g/s, g/m or g/h), or the volume flow rate (mL/s, mL/m or mL/h) by entering the density of the material—up to 10 densities can be saved to the device. Both the display refresh rate and calculation time (set either manually between 1 second and 1 hour or automatically according to the selected level of responsiveness to weight/flow rate variation*) are regulated by the same internal clock of the balance, allowing measurements to be precisely performed without

the time disparity problem described above.

◆ Patent

pending

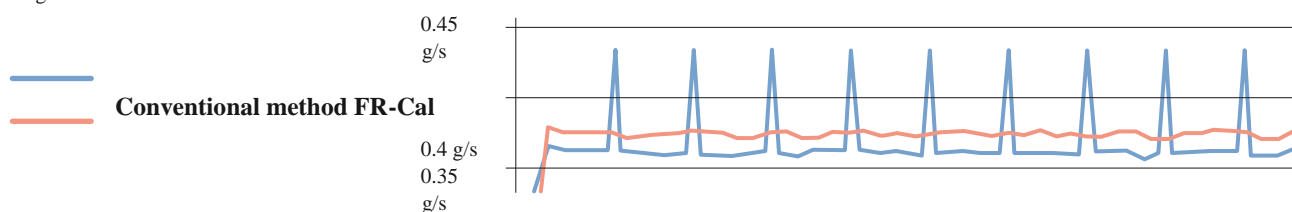

Flow rate measurement using FR-Cal as opposed to the conventional method

FR-Compare

The balance indicates whether the flow rate is maintained within the designated limits (either 3 levels or 5 levels). The results can be output using the optional GXA-04 interface.

WinCT-FRD (freeware)

This software enables a PC to simultaneously display the weight and flow rate values transmitted from the balance on a two axis graph so that you can see their changes in real time. The graph can be printed out using a printer or saved as an image file, whereas the recorded data can be saved in CSV or TXT format.

Data management, documentation and compliance

Tare memory

The tare value can be saved in non-volatile memory. When this function is activated, the power-on re-zero/tare is turned off. Therefore, even if the power supply is cut off while performing, for example, flow rate measurement, the weight value displayed before the power off will be displayed as the balance is turned on again.

User access control (UAC) and key lock to prevent misuse

The balance can be password-protected in two ways: The first way is to limit the use to authorized individuals (up to 11 including one administrator—the administrator can perform all operations while other users are limited to measurements and calibration*⁶ only) by setting a password for each user. The second way is to set a password just for the administrator and anyone else can use the balance without entering a password but for measurements and calibration*⁶ only.

Moreover, upon receiving a command to disable its keys, the balance becomes operable only by sending commands from an external device such as a PC.

*⁶ The administrator can inhibit calibration also so that others can perform measurements only.

Automatic minimum weight calculation and implementation

You can enter the minimum weight into the balance by either direct key input, using the result of QuickMin-S described earlier, or having the balance calculate the minimum weight from 10 repeated measurements of an actual, external weight (as with QuickMin-S, the tolerance can be set to either 0.1% pursuant to USP Chapter 41 or 1%). The stored value can always be called up to see/change or output together with timestamp. When QuickMin-S or an external weight was used, the calculation data is also output.

Min-S Alert

To ensure that the measured sample amount meets the minimum weight requirement, the balance can display an alert until the sample amount reaches the value entered as the minimum weight.*⁷

*⁷ When g is selected as the unit of measure only **Blinking**



minimum weight alert

Universal Flexi Coms (UFC)

This function enables you to customize printout content and layout by editing and sending commands (UFC setting commands) to the balance. Following the commands, the balance creates data to be output to either a printer capable of dump printing such as the AD-8127 compact printer or a commercially-available label printer*⁸ for barcode printing.

*⁸ A label printer that supports ZPL/ZPL II

WinCT-UFC (freeware)

With this software, you can easily edit UFC setting commands on a PC and send them to a balance/scale that has a UFC function, such as A&D Apollo. All that is required is to select data (e.g. weighing result, date, time, ID number, etc.), enter text and adjust the layout while checking the preview screen, which the software automatically converts to UFC setting commands. For label printing, users can choose one of three kinds of barcodes; namely, QR code, Data Matrix code and Code 39.

Gross/Net/Tare output

On receiving a command or with key operation, the balance can also output the gross, net, and tare values.

Statistical calculation function (SCF)

A&D Apollo can display/output statistical calculation data including the number of data, sum, maximum, minimum, range (maximum-minimum), average, standard deviation, coefficient of variation and relative error to facilitate the analysis of measurements.

GLP/GMP/GCP/ISO compliant output

For documentation requirements, the balance manufacturer, model, serial number, ID number, date + time,*⁹ space for signature for calibration report, calibration test report, and title & end blocks for a series of weighing results can be output.

*⁹ When the AD-8127 compact printer is used, it is possible to use its clock & calendar function instead of the balance's to print date + time. This allows you to prevent falsification of the timestamp using the password lock function on the printer side as you prefer.

Data memory

A&D Apollo has a capacity to store up to 200 weighing results + 50 calibration results (all with timestamp), and 50 unit masses to be used in counting mode for cases when no external memory device is available. The stored weighing results or calibration results can be output to a printer

Other advanced features



RS-232C and USB interfaces as standard

For the USB interface, you can toggle between the Quick USB mode (plug-and-play with weighing data output to a PC only) and the Virtual COM mode (for bi-directional communication* 10) with internal settings. A USB cable is provided as standard.

*10 A special driver downloaded from the A&D website needs to be installed on the PC (except for those with Windows 10).

Reverse backlit LCD display

The contrast of black and white provides excellent visibility even in poorly-lit areas and also prevents eye fatigue.



Bright Bubble

The large, front-mounted spirit level is easy to see with or PC in one batch.

LED illumination, which blinks for 5 seconds after the down smoothly using large thumbwheels display is turned on to call for attention to make sure the set in higher position. balance is level.



Security slot

An off-the-shelf (such as Kensington) anti-theft lock can be used to prevent the balance from being lost.

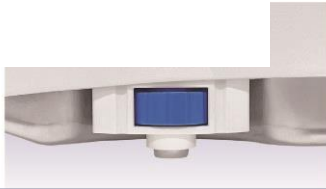



Fly-Thumbwheel

The leveling feet can be adjusted up or

Options*11

GXA-03	GXA-04	2nd RS-232C interface
		Comparator relay output/buzzer/external key input interface
		Enables signaling check weighing results (3 or 5 levels) by buzzer and/or external comparator (traffic) lights. It also has two jacks for separately-sold foot switches.
GXA-06		Analog output interface (factory-installed/dealer option)
		0-1 V, or 0.2-1 V for conversion to 4-20 mA.
FXi-08		Ethernet interface
GXA-09		Built-in rechargeable battery (factory-installed/dealer option)
		10 hours of charging for 14 hours of operation (the remaining battery level will be indicated on the display). The balance can be used while recharging the battery.
GXA-10*12		Large glass breeze break
GXA-12		Animal weighing pan (0.001/0.01/0.1 g readability models of 320 g capacity or higher) Use together with the animal weighing (average & hold) mode.
GXA-13	Density determination kit for the 0.001 g readability models	Density determination kit for the 0.0001 g readability models
GXA-17*13		Large glass breeze break with built-in fanless ionizer and external IR switch
GXA-23-PRINT		External key input interface + the AX-SW137-PRINT foot switch
GXA-23-REZERO		External key input interface + the AX-SW137-REZERO foot switch
GXA-23-PLUG		External key input interface + the AX-T-314A-S plug
GXA-24		USB host interface (factory-installed/dealer option)
		Accepts an off-the-shelf USB flash drive to save weighing results in CSV format.

Accessories

AD-1641	Air flow logger	
GXA-25	Fanless ionizer of Quick Ion technology	Make weighing the sample in air and in water quicker, easier and more precise. A&D Apollo can then perform a density calculation automatically.
	Power is supplied from the balance. Activated for a set duration with an embedded IR sensor.	
GXA-26	External IR switch	
	For touchless operation of print or re-zero (tare).	
		* 11 Only one of GXA-03, GXA-04, GXA-06, FXi-08, GXA-09, GXA-17, GXA-23-PRINT/REZERO/PLUG, GXA-24, GXA-25 or GXA-26 can be installed (meaning that GXA-03, GXA-04, GXA-06, FXi-08, GXA-09, GXA-23-PRINT/REZERO/PLUG, or GXA-24 cannot be installed in the GX-AE series without first removing its interface for the built-in fanless ionizer).
		* 12 Provided as standard for the 0.0001 readability models of the GX-A/GF-A series.
		13 Provided as standard for the GX-AE series.
AD-1682	Rechargeable battery unit	
AD-1683	Static eliminator*14	
AD-1684A	Electrostatic field meter	
AD-1687	Weighing environment logger	
AD-1688	Weighing data logger	
AD-1689	Tweezers for calibration weight	
AD-1691	Weighing environment analyzer	
AD-8127	Compact printer	
AD-8526	Serial/Ethernet converter	
AD-8920A	Remote display	
AD-8922A	Remote controller	
AX-BM-NEEDLESET	Electrode unit for ionizer (4 pcs)	
AX-GXA-31	Main unit cover (5 pcs)	
AX-SW137-PRINT	Foot switch for print	
AX-SW137-REZERO	Foot switch for re-zero	
AX-USB-9P	Serial/USB converter with cable	

*14 Power needs to be supplied from an AC adapter. Recommended when A&D Apollo has another option than GXA-17 or GXA-25

installed.

AD-8529PC/PR-W Bluetooth® converters

Enable wireless communication between a balance/scale and a PC/printer using Bluetooth® technology* 15 (line-of-sight distance approx. 10 m when there is no radio wave interference).

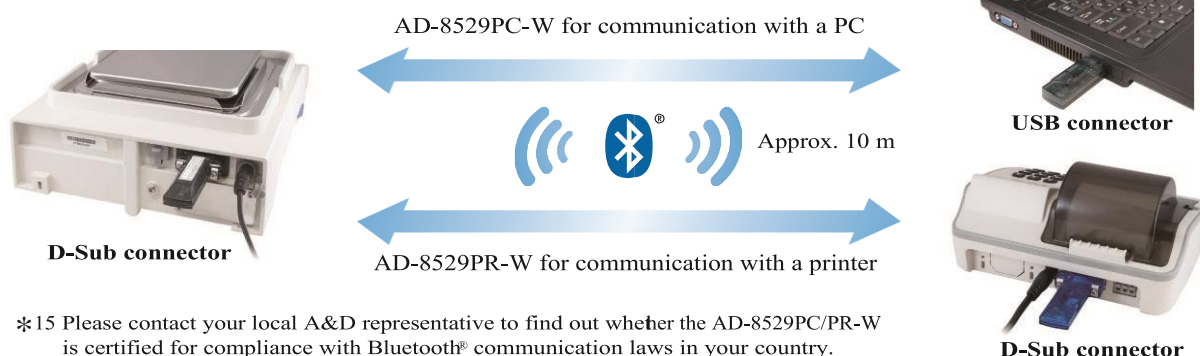

*15 Please contact your local A&D representative to find out whether the AD-8529PC/PR-W is certified for compliance with Bluetooth® communication laws in your country.

Specifications

GX-AE (0.0001g)

GX-A/GF-A (0.001g)

Models	GX-224AE	GX-203A GF-203A	GX-403A GF-403A	GX-603A GF-603A	GX-1003A GF-1003A	GX-1603A GF-1603A
Capacity	220 g	220 g	420 g	620 g	1100 g	1620 g
Readability	0.0001 g	0.001 g				
Repeatability (standard deviation)	0.0001 g	0.001 g				
Minimum weight ⁸⁾ (typical)	120 mg	1.4 g				
Linearity	±0.0002 g	±0.002 g				±0.003 g
Stabilization time (when set to FAST under a good environment)	Approx. 2 sec (200 g) Approx. 1.5 sec (100 g)	Approx. 1 sec Approx. 0.8 sec (5 g)				Approx. 1.5 sec Approx. 0.8 sec (5 g)
Sensitivity drift	±2 ppm/°C (10 to 30 °C/50 to 86 °F, when automatic self calibration is OFF)					
Accuracy immediately after internal calibration (for the GX-A series) ^{8)H}	N/A	±0.010 g				±0.010 g (1000 g)
Operating environment	5 to 40 °C (41 to 104 °F), 85%RH or less (no condensation)					
Display refresh rate	5 times/sec, 10 times/sec or 20 times/sec					
Units of measure ⁹⁾	g (gram), oz (ounce), lb (pound), lb-oz (pound-ounce), ozt (troy ounce), ct (metric carat), mom (momme), dwt (pennyweight), gr (grain), pcs (counting mode), % (percent mode), SG (density mode), and a user-programmable unit					
Counting mode	Minimum unit mass	0.0001 g	0.001 g			
	Number of samples	5, 10, 25, 50 or 100 pieces	5, 10, 25, 50 or 100 pieces			
	Minimum 100% reference mass	0.0100 g	0.100 g			
Percent mode	% readability	0.01%, 0.1% or 1% (depends on the reference mass stored)				
Communication interface	RS-232C and USB					
Applicable calibration weight value	50 g 100 g 200 g	50 g 100 g 200 g	50 g 100 g (100 g interval) 400 g	50 g 100 g (100 g interval) 600 g	50 g 100 g (100 g interval) 1000 g	50 g 100 g (100 g interval) 1600 g
Weighing pan size	Ø90 mm		128 × 128 mm			
External dimensions	259 (W) × 358 (D) × 332 (H) mm		212 (W) × 317 (D) × 171 (H) mm (including the small plastic breeze break)			
Net weight	Approx. 7 kg		Approx. 5 kg			
Power supply / consumption	AC adapter / approx. 30 VA					
Models	GX-2002A GF-2002A	GX-4002A GF-4002A	GX-6002A GF-6002A	GX-6001A GF-6001A	GX-10001A GF-10001A	
Capacity	g	g	g	g	g	
Readability	0.01 g				0.1 g	
Repeatability (standard deviation)	0.01 g				0.1 g	
Minimum weight ⁸⁾ (typical)	g				g	
Linearity	±0.02 g		±0.03 g		±0.1 g	
Stabilization time (when set to FAST under a good environment)	Approx. 1 sec Approx. 0.8 sec (50 g)				Approx. 1 sec Approx. 0.8 sec (500 g)	
Sensitivity drift	±2 ppm/°C (10 to 30 °C/50 to 86 °F, when automatic self calibration is OFF)					
Accuracy immediately after internal calibration (for the GX-A series) ^{8)H}	±0.10 g	±0.15 g	±0.15 g (5000 g)		±0.5 g (5000 g)	
Operating environment	to 40 °C (41 to 104 °F), 85%RH or less (no condensation)					
Display refresh rate	times/sec, 10 times/sec or 20 times/sec					

Units of measure⁸⁾	g (gram), oz (ounce), lb (pound), lb-oz (pound-ounce), ozt (troy ounce), ct (metric carat), mom (momme), dwt (pennyweight), gr (grain), pcs (counting mode), % (percent mode), SG (density mode), and a user-programmable unit				
Counting mode	Minimum unit mass		Number of samples		
	0.01 g		5, 10, 25, 50 or 100 pieces		0.1 g
Percent mode	Minimum 100% reference mass				
	1.00 g				10.0 g
	0.01%, 0.1% or 1% (depends on the reference mass stored)				
Communication interface	RS-232C and USB				
Applicable calibration weight value	g g2000 g	g g (1000 g interval) g	g g (1000 g interval) g	g g (1000 g interval) g	g g (1000 g interval) g
Weighing pan size	× 165 mm				
External dimensions	212(W) × 317(D) × 93(H) mm				
Net weight	Approx. 5 kg				
Power supply / consumption	AC adapter / approx. 30 VA				

GX-A/GF-A (0.01/0.1g)

***iiii Under stable environment (no rapid temperature/humidity change, vibration, draft, magnetism, static, etc). The mass of the internal weight may vary with age. One additional unit from tael (Singapore/HK jewelry/Taiwan/China), tola or Newton can be added upon request. Pursuant to the United States Pharmacopeia (USP), Chapter 41

Dimensions (mm/inches)

GX-224AE

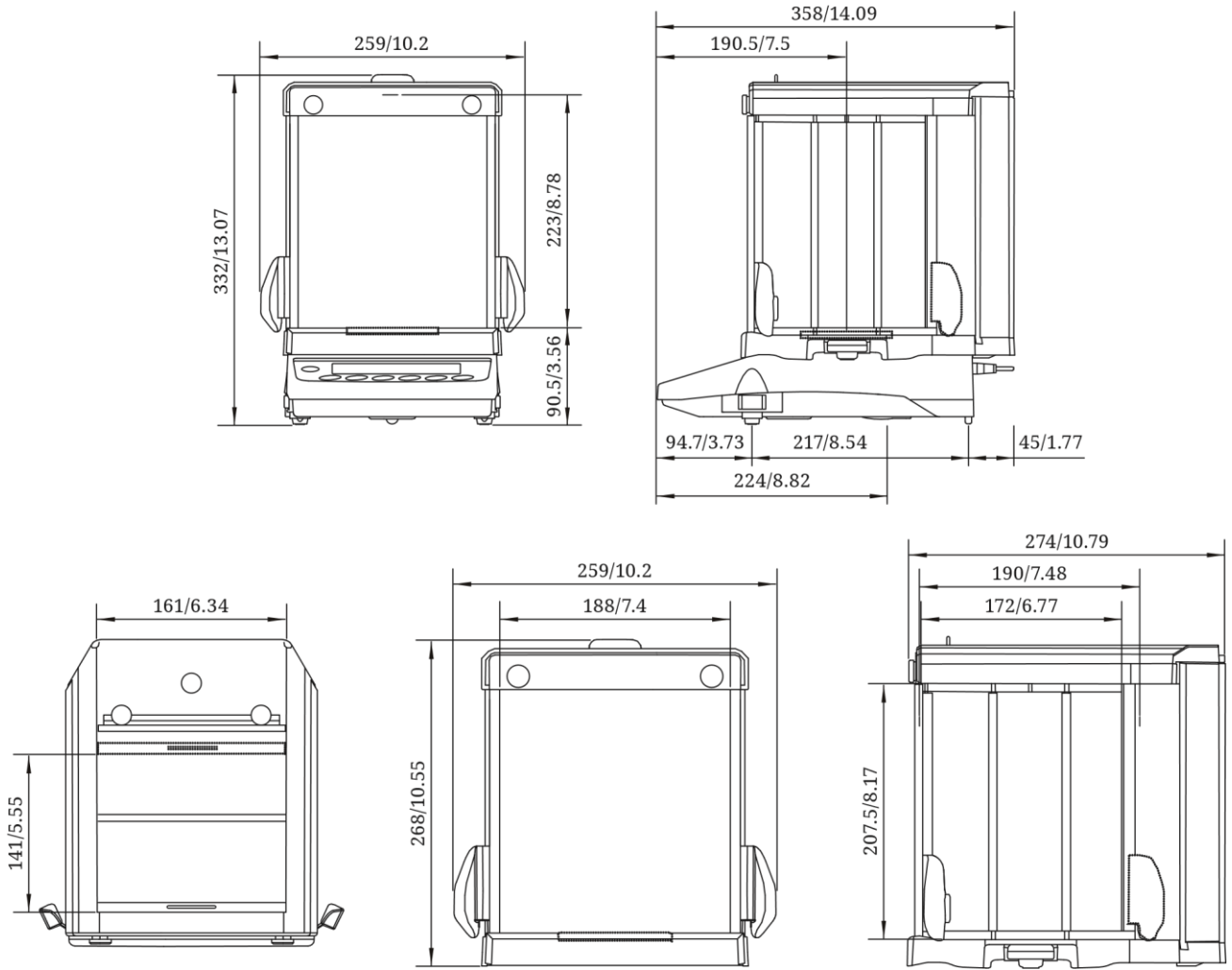

Dimensions (mm/inches)

GX-203A / GX-403A / GX-603A /
GX-1003A / GX-1603A
GF-203A / GF-403A /
GF-603A / GF-1003A / GF-1603A

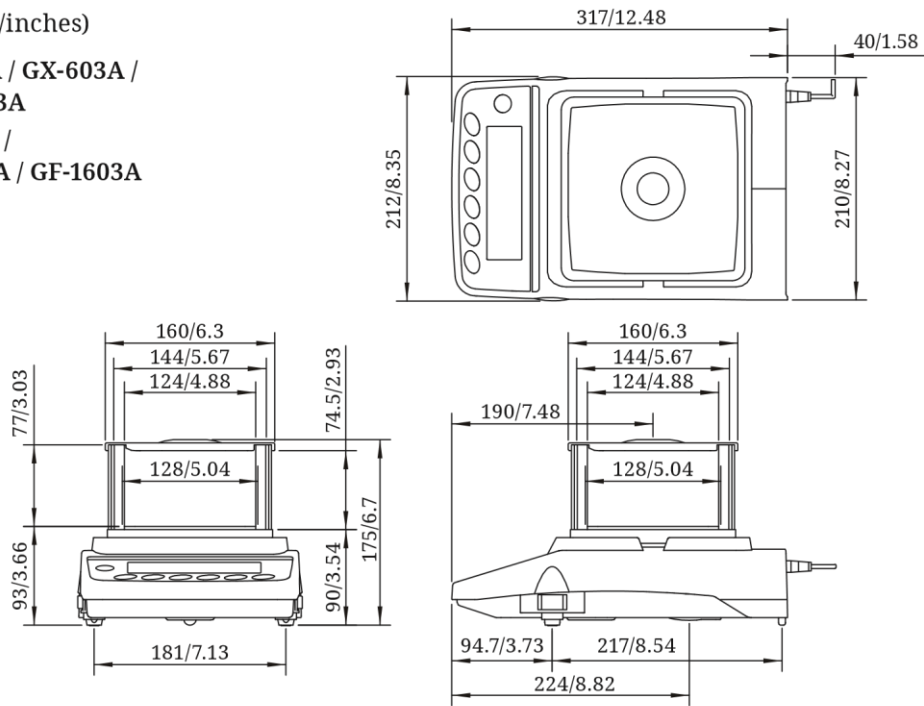

GX-2002A / GX-4002A / GX-6002A /
GX-6001A / GX-10001A
GF-2002A / GF-4002A /
GF-6002A / GF-6001A / GF-10001A

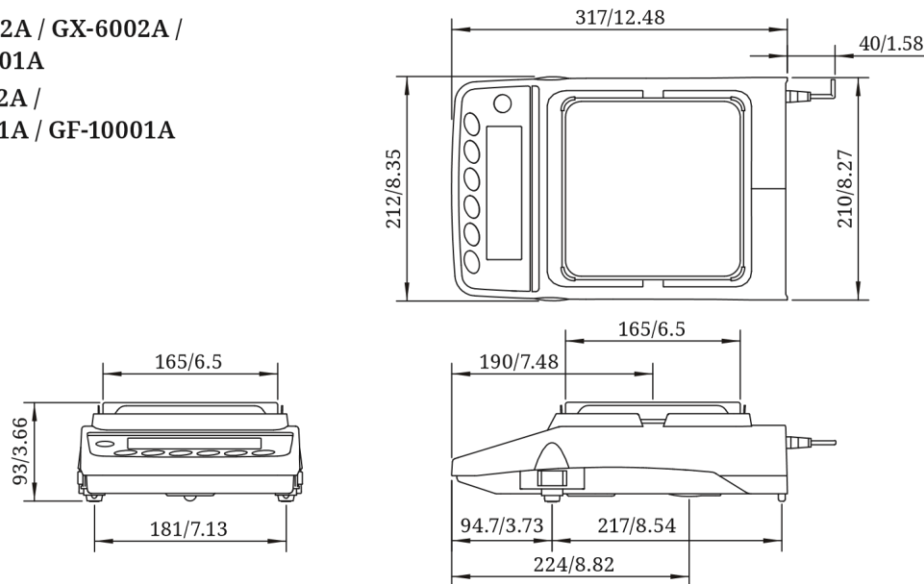

Discover Precision



Proudly Sold & Serviced By:

Able Scale Co Pty Ltd

Ph: 1300 731 360

21 Green St Thomastown VIC. 3074

find us on the web: www.ablescale.com.au