

Outstanding Performance, Flexible Configuration and Reliable Results

The MB23 provides precise moisture content determination at an unbeatable value. With a large backlit LCD display, standard RS232 port, 110g capacity with a readability of 0.01g/0.1% and a non-glass infrared heating element, the MB23 offers moisture analysis for any budget.

Standard Features Include:

- **Glass-less infrared heating increases efficiency for faster results.**
The OHAUS MB23 provides accurate results at 0.1% readability. And with your choice of infrared heating, they are ideal for many applications that require IR heating elements and measurements to 0.1%.
- **User-friendly touch-button design for easy operation.**
Set up and operation is extremely easy. Just press and hold the temperature or time buttons to set drying parameters, add your sample and begin the test process.
- **Compact design suits any workspace.**
The compact footprint (17 x 13 x 28 cm) of the OHAUS MB23 is designed to take up less space. Their easy-to-clean heating chamber is ideal for frequent use and inexpensive maintenance.

MB23 Moisture Analyzer

Model	MB23
Capacity	110g
Repeatability (Std Dev) (g)	0.3% (3g sample) 0.2% (10g sample)
Readability	0.1% / 0.01g
Sample Size	3g to 20g typical, 0.5g min.
Interface	Bidirectional RS-232
Timer	1 - 99 minutes, 30-second increments to 60 minutes
Heating Technology	Infrared (no glass)
Temperature Range	50°C to 160°C in 5° increments
Power	100 to 240 VAC, 50/60 Hz
Tare Range	To capacity by subtraction
Operating Temperature Range	5° to 40°C
Display Type	Custom backlit LCD
Displays	% moisture or % solids or weight (g), temperature, time
Pan Size (Diameter)	Φ 90 mm
Dimensions (W x H x D)	107 x 130 x 280 mm
Net Weight	2.3 kg
Shipping Weight	3.9 kg

Compliance

- **Product Safety:** IEC/EN 61010-1, IEC/EN 61010-2-010
- **Electromagnetic Compatibility:** IEC/EN 61326-1 Class B, Basic environments

Other Standard Features & Equipment

3 shut off criteria (manual, timed or auto), 1 standard heating profile, 50° to 160° C heating range (5° C increments)

Accessories

Temp. Calibration Kit, MB Series	11113857
In-Use-Cover, MB23 MB25	80252475
Holder, Pan, MB Series	80252476
Pan, Reusable, Set(3), 7mm, MB Series.....	80252478
Pan, Reusable, Set(3), 14mm, MB Series.....	80252478
Aluminum pan packed with 50 pcs.....	30585411
Filter, Glass Fiber, Set(200)	80850087
Cage, sample.....	80252477
Anti-Theft Device, MB AX EX Scout	80850043
Printer, Impact, SF40A	30045641
Interface Kit, RS232-USB	30304101

Dimensions

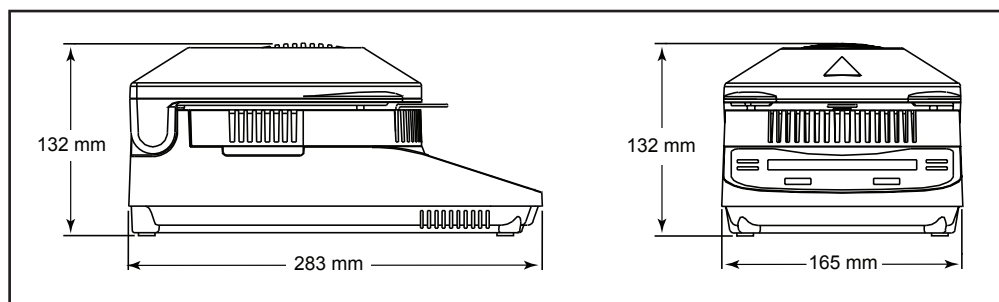

Proudly Sold & Serviced By:
Able Scale Co Pty Ltd
 Ph: 1300 731 360

21 Green St Thomastown VIC. 3074

find us on the web: www.ablescale.com.au

OHAUS Asia/Pacific Headquarters
 7F, Block 33, 680 Guiping Road
 Shanghai 200233
 China

e-mail: APmarketing@ohaus.com
 Tel: +86 21 64855408

www.ohaus.com

The management system governing the manufacture of this product is ISO 9001:2008 certified.

SAP Literature #: 30385538

