

VS 12 D / VS 12 D-V — AUTOMATIC SLICER

The VS series feature a vertical carriage with a positive product feed. This allows for consistent, thin slices. The Semi and Fully automatic versions have a built-in diagnostic program for easy troubleshooting. The VS series incorporates all the safety features one expects with Bizerba products.

→ VS 12 D – SEMI-AUTOMATIC SLICER

- Shingle, Stack, Circular patterns.
- Shingling in 3 rows, traditional or transverse. Multi-layer.
- Stacking. Up to 4 stacks with one product. 2.5" max. height.
- Circular presentations in 3 diameters.
- Adjustable speed and spoke.
- Built in diagnostic program.

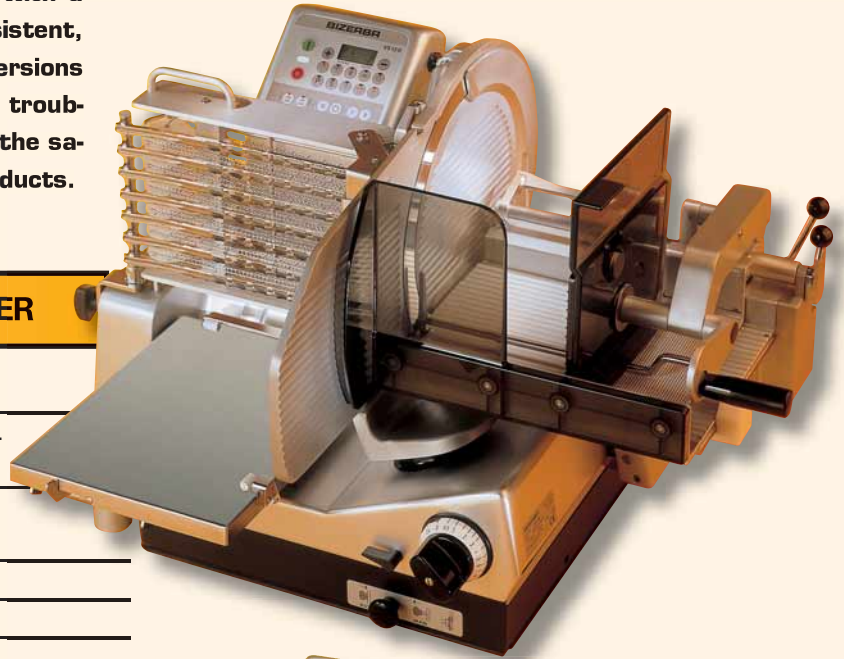

→ VS 12 D-V – FULLY AUTOMATIC SLICER

- All the features of VS 12 D
- Larger carriage for full production. 20" x 10.5"
- Will fit 15" long product without re-clamping.

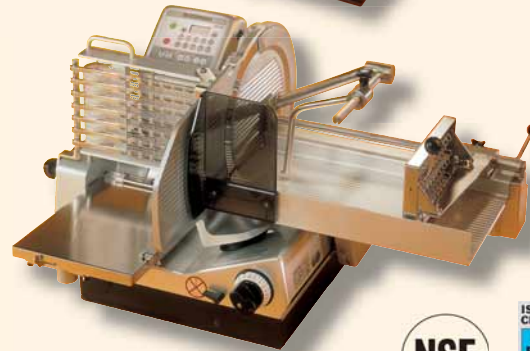

→ BEST BLADE IN THE INDUSTRY

The unique design of our blade produces clean and consistent slices. The hardness results in a long lasting sharp edge. The life of the blade is dramatically longer than the competition. The circumference translates into an additional 4" of blade passing through the product per revolution. Our standard blade is the hardest, thinnest, largest, straightest blade in the industry.

- 13" diameter, chromium coated hard alloy.

- 60-62 Rockwell hardness at the edge.
- Top quality gravity feed slicer with low-profile carriage for heavy product.

Options:

- **Round platter for star shaped presentations**
- **Mobile Stand for the correct working height**



→ TECHNICAL DATA

Current type	Voltage	Frequency	Rated	Power
	V	Hz	amperage A	consumption kW
→ 1-phase AC:	230	50	2.5	0.575
	120	60	4.2	0.504
→ 3-phase AC:	230/400	50	1.9/1.38	0.552
→ Blade diameter:	13" (330 mm)			
→ Blade speed:	266 r.p.m.			
→ strokes/min:	full	mid	short	
	30/40/50	35/48/58	60/68/75	
→ Slice thickness, infinitely variable:	0.02" to 0.94" (0.5 to 24 mm)			
→ Protection class:	IP 33			
→ Installation area:				
- VS 12 D	(L x W) 20.3" x 16.9" (515 x 430 mm)			
- VS 12 D-V	(L x W) 20.3" x 16.9" (515 mm x 430 mm)			
→ Space required:				
- VS 12 D	(L x W) 31.5" x 38.6" (800 mm x 980 mm)			
- VS 12 D-V	(L x W) 32.5" x 40.9" (825 mm x 1040 mm)			

→ Dimensions packed:

(L x W x H) 33.5" x 32.3" x 27.6"
(850 x 820 x 700 mm)

→ Weight:

- VS 12 D approx. 165 lbs /75 kg (net)
approx. 191.4 lbs/84 kg (gross)
- VS 12 D-V approx. 165 lbs/75 kg (net)
approx. 192 lbs/87 kg (gross)

→ Receiving tray:

10" x 13.6" (254 x 346 mm)

→ Paper size:

1/8 sheet – 9.8" x 14.8" (250 x 375 mm)

→ Table displacement:

6.3" (160 mm)

→ Additional equipment:

Round platter for star-shaped product layout, Teflon blade, product clamping device

→ Dimensions inches (mm):

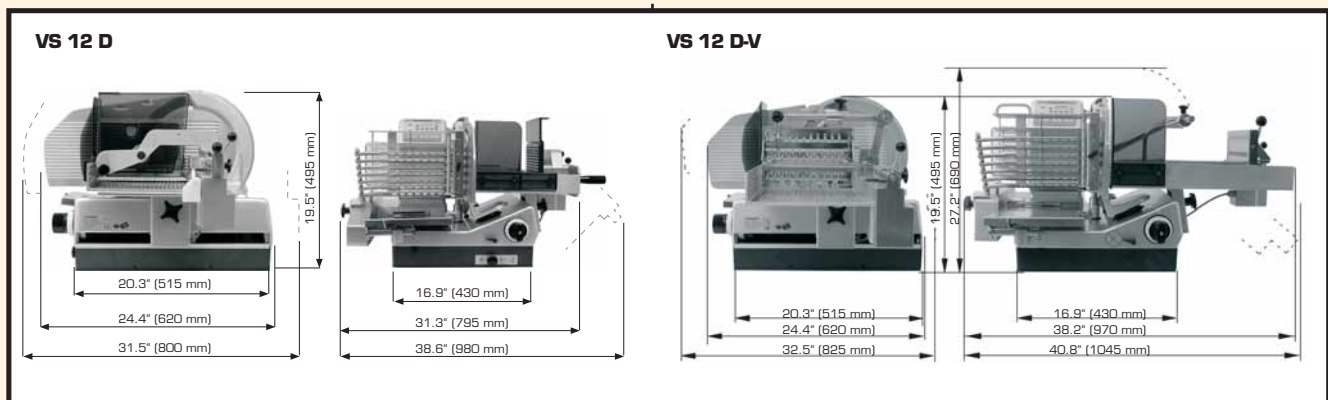

→ WARRANTY

The VS 12 D/VS 12 D-V carries a one-year, on-site parts and labor warranty against any flaws in materials and workmanship. This period begins with the date of purchase and, provided the unit is used properly in accordance with our instructions, is in full effect for one year from that date. Any work to be performed under this warranty must be performed between the hours of 8:00 a.m. and 4:30 p.m. local time, Monday to Friday. Bizerba will not pay overtime charges for work performed other than during normal business hours. Accessories have a 30-day replacement or repair warranty for the period beginning on the date of purchase. Damages incurred in transit or from installation error, accident, alteration or misuse are not covered. Transit damages should be reported to the carrier immediately. Bizerba shall not be liable for any consequential, compensatory, incidental, or special damages. All warranty work must be performed by a factory authorized Bizerba Representative.