

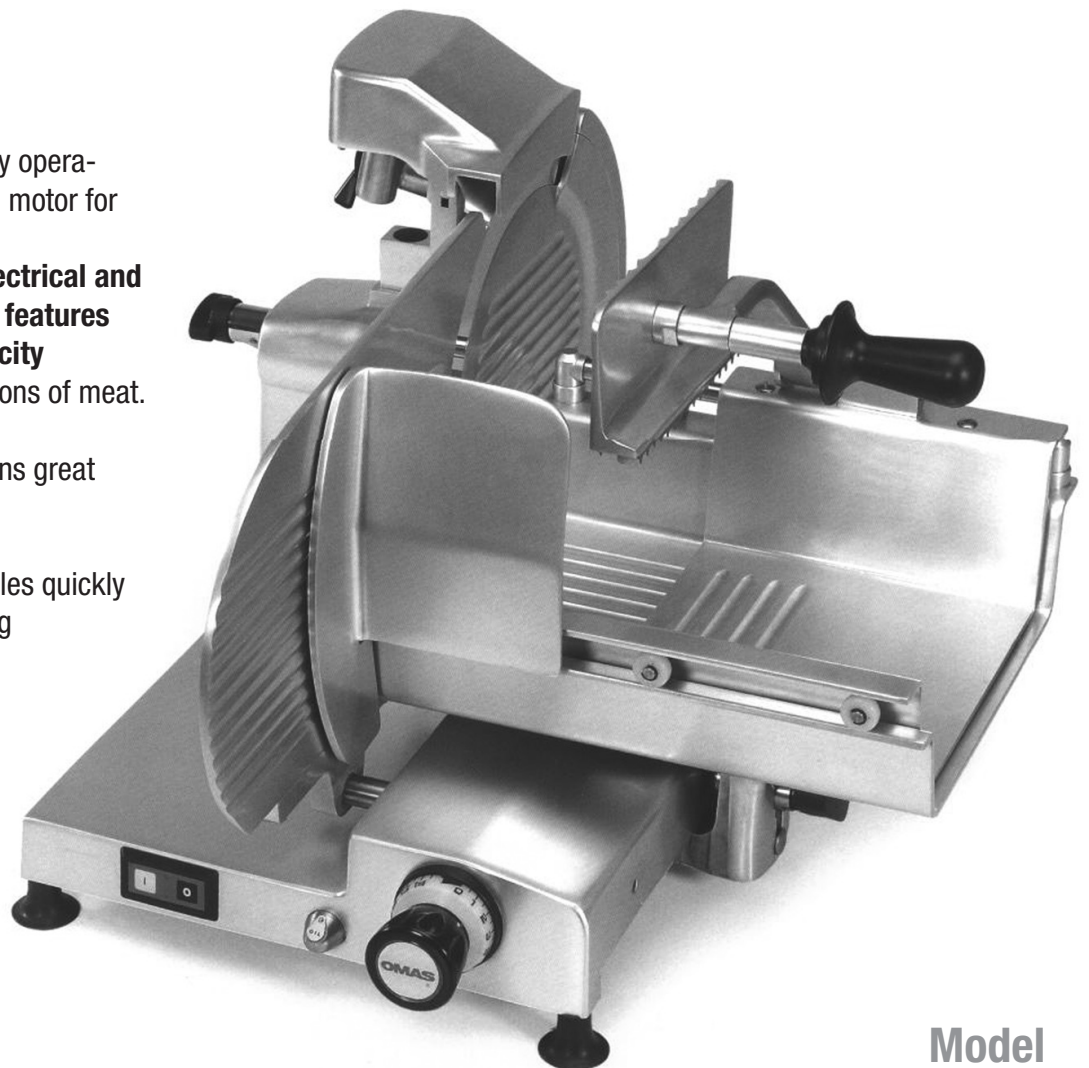

The H Series flatbed manual slicers are heavy duty machines designed for slicing fresh meat. The powerful motor and gear-driven blade mean the H Series can operate in even the busiest high-volume commercial kitchen.

- **Gear Drive**
Powerful, heavy duty operation with fan-cooled motor for continuous service
- **Comprehensive electrical and mechanical safety features**
- **Large slicing capacity**
Ideal for larger portions of meat.
- **Built in sharpener**
Easy operation means great cuts every time
- **Easy cleaning**
Machine disassembles quickly for effective cleaning
- **CE approved**



Model
H Series
Flatbed Slicers

Model H Series Flatbed Slicers

SPECIFICATIONS	H25E	H30E	H35E	H37E
Blade (mm)	250	300	350	370
Motor	240V single phase, 50Hz			
Dimensions				
Height (mm)	440	490	530	570
Length	630	720	840	890
Width	610	640	720	810
Slice Capacity				
Rectangular (mm)	240x180	280x230	310x270	350x280
Circular/Diameter (mm)	180	230	270	280
Max. Slice thickness (mm)	15	15	15	15
Net weight (kg)	39	41	43	45



The built-in sharpener is simple and safe to operate.

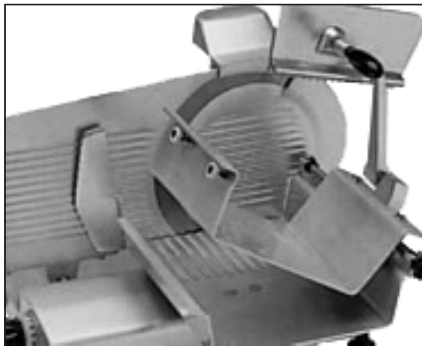

The generously-sized meat tray can handle whole sides of bacon, and the smooth double-action movement reduces slicing effort.

The Model H Flatbed slicer has been designed especially for slicing fresh meat.

With its large capacity meat table, the versatile H Series can handle any meat product - from small salami and sausages, up to full size sides of bacon.

- Manufactured in stainless steel and anodised aluminium to resist the corrosive effects of salts and acids;
- Constructed for easy and friendly cleaning;
- Micrometric adjusting knob allows for cutting of slices up to 15mm (option for 25mm slice - see below);
- Built-in dual action sharpener ensures a long lasting razor sharp knife;
- Forced ventilation to motor;
- Gear driven blade;
- Safety cutout switches for blade operation and blade cover.

Options:

- 6 Slice cutting to 25mm
- 8 Portioner: weight indicator
- 16 Digital slice counter
- 56 Receding feet
- 57 High feet
- 63 Stainless steel removable tray
- 97 Teflon coating (thickness plate, blade and blade cover)
- 130 Guarded, auto-locking blade removal device

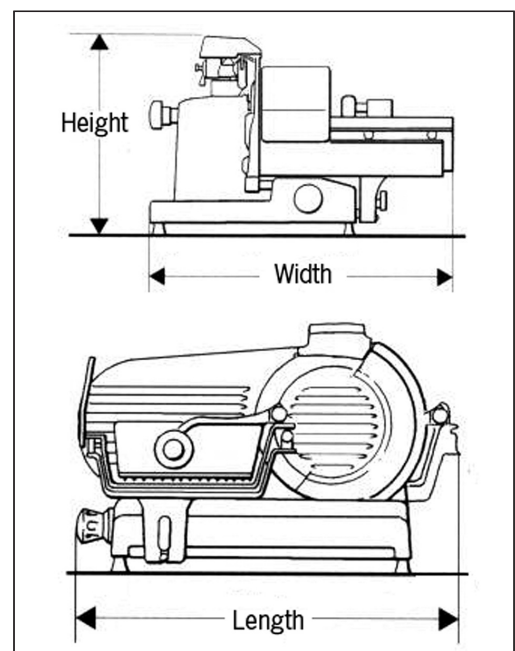

SALES AND SERVICE



Proudly Sold & Serviced By:

Able Scale Co Pty Ltd

Ph: 1300 731 360

21 Green St Thomastown VIC. 3074

find us on the web: www.ablescale.com.au



Brice Australia Pty. Ltd.
ABN 71 413 589 669

100% Australian owned and operated

This document may not be reproduced, in whole or in part, by any means without the prior express written permission of the copyright owner. Brice and the BRICE logotype are trademarks of Brice Australia Pty. Ltd. Printed in Australia.

Copyright © 2006 Brice Australia Pty. Ltd.

www.briceaust.com.au